



GOUTTIERE NOIR ANTHRACITE

FIRST[®]
PLAST - FRANCE

FABRICANT PLASTIQUE BÂTIMENT



GOUTTIERE NOIR ANTHRACITE

COEX[®]
I N N O V A T I O N



NOIR ANTHRACITE
RAL 7021

FIRST, fabricant de gouttières en PVC depuis 1974, est heureux de présenter la gamme de gouttières COEX INNOVATION, avec caractéristiques uniques dans son secteur.

CARACTÉRISTIQUES TECHNIQUES

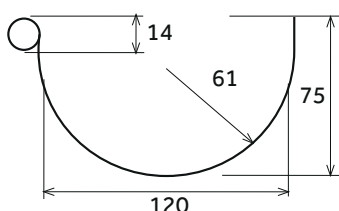
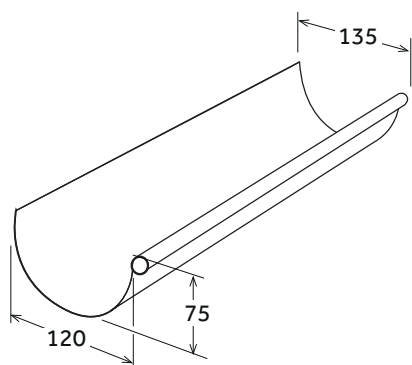

Section l'évacuation		cm ² . 55,6
Largeur		cm. 13,5
Développé		cm. 25
Raccordement		à joint / à coller



GREEN
Recyclable
en non polluant



DURABLE



STABLE
aux UV



RESISTANTS
aux intempéries et
aux chocs thermiques



ANTICHOCK



RESISTANTS



LEGERES et FACILES
à installer



Des ouvres qui
defient le TEMPS

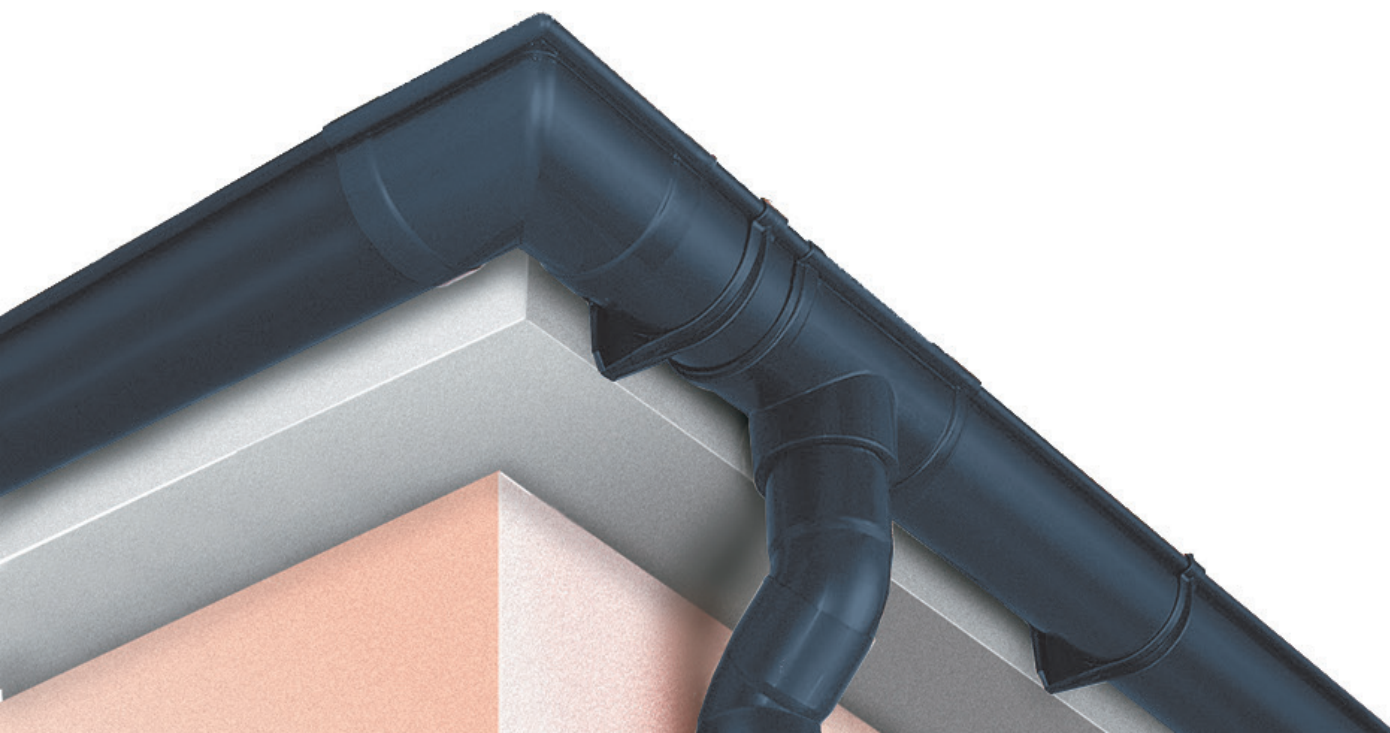

GAMME GOUTTIERE ET ACCESSOIRES



CODE: GRN125AN2



CODE: CAN80S3



CODE: TDAN82



CODE: AN125AN



CODE: CIPM125AN



CODE: CIP125AN



CODE: GNE125AN



CODE: TN125AN



CODE: TGS125AN



CODE: CL87080AN



CODE: CL67080AN



CODE: CL45080AN



CODE: DL67080AN



CODE: GSS125AN



CODE: FFAN080080



CODE: RAPF186AN